



TECHNICAL DATA

DIESEL GENERATING SET

MPMC POWERTECH CORP.

60HZ

MCS20S-2 / MCS20-2

Features

- Compact structure with high-strength chassis;
- Easy operation and maintenance, Low cost;
- Excellent performance damping system;
- Compliance with international electrical safety standards of electrical system;
- 8 hours base tank;
- High-performance maintenance-free batteries with isolation switch
- 50°C Radiator;
- Top lifting, Forklift bottom hole design, easy to transport;
- Industrial muffler;
- Noise reduction structure , Low noise;
- Convenient power output interface;
- IP56 (control system)
- Customized design for user
- Structure optional: Open (MCS20-2) Sound-proof (MCS20S-2)

Reference images, the actual shall prevail

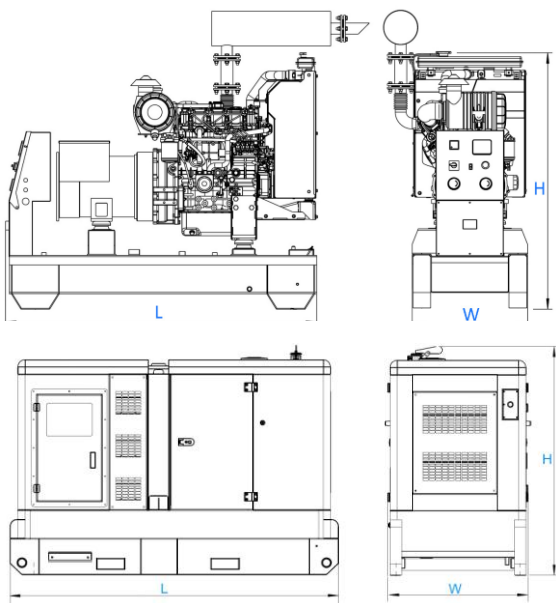

Dimension and Weight

Generating set model	MCS20S-2	MCS20-2
Length(L) (mm)	2600	1946
Width(W) (mm)	1130	734
Height(H) (mm)	1650	1272
Dry weight (k g)	1262.5	748
Tank capacity (L)	190	162

Genset Technical Data

Output frequency	60 HZ
Rated speed	1800 rpm
Prime power	18 KW
Standby power	20 KW
Rated voltage	480 V
Phase	3
Noise dB(A) @7m	70
Engine model	4B3.9-G2
Alternator model	PI 144D
Fuel consumption of 100% load	6.7 Litres/h
Fuel consumption of 75% load	5.2 Litres/h
Voltage regulation rate	≤±1%
Random voltage variation	≤±1%
Frequency regulation rate	≤±5%
Random frequency variation	≤±0.5%

Engine Specifications			
Engine model	4B3.9-G2		
Engine manufacturer	Cummins		
Number of cylinders	4		
Cylinder arrangement	In-line		
Cycle	Four stroke		
Aspiration	Naturally		
Bore Stroke (mm mm)	102 x 120		
Displacement (Liter)	3.9		
Compression Ratio	16.5:1		
Prime power/speed (kW/RPM)	27 /1800rpm		
Standby power/speed (kW/RPM)	30 /1800rpm		
Speed governor	Electrical		
Cooling system	Forced Water Cooling Cycle		
Steady speed droop (%)	≤1%		
Total lubrication system capacity (L)	11		
Coolant capacity (L)	7.2		
Fuel consumption at 100% load (g/kWh)	229 (at 1800RPM)		
Starter motor	DC24V		
Alternator	DC24V		
Alternator Specifications			
Rated frequency	60 Hz		
Rated speed	1800 rpm		
Alternator model	PI 144D		
Rated output prime power	20 kW		
Efficiency (%)	85.3%		
Phase	3		
Rated voltage	480 V		
Exciter type	Self excitation, Brushless		
Power factor	0.8		
Voltage adjust range	≥5.0%		
Voltage regulation NL-FL	≤±1.0%		
Insulation grade	H		
Protection grade	IP23		
Xd DIR. AXIS SYNCHRONOUS	1.68		
X'd DIR. AXIS TRANSIENT	0.17		
X''d DIR. AXIS SUBTRANSIENT	0.11		
Xq QUAD. AXIS REACTANCE	0.81		
X''q QUAD. AXIS SUBTRANSIENT	0.18		
Optional			
Optional Alternator brand	Leroy Somer	mecc alte	MPMC
Optional Alternator model	LSA 40 M5	EC028-1LN/4	LYG 184E
Exciter type	Self-excited	Self-excited	Self-excited
Rated output prime power	20KW	19.2KW	24KW

Control System

NSM-100-3110 (Standard)

All MPMC Gensets have a control cabinet (the Deepsea control module DSE3110 as standard) mounted on isolated support.

Main Features

- Manual and automatic mode
- Parameter configuration via RS-232 serial communication
- Remote control automatic start/shutdown
- Optional ECU control
- Optional CAN engines
- Optional speed sensor access
- PLC programming
- Operating temperature: -20°C to 70°C
- IP56 Rating
- Back-lit icon LCD display
- Power Save mode
- CAN and Magnetic Pick-up/Alt. versions available (specify on ordering)
- PC configurable
- 6 Digital inputs
- 4 Outputs (2 configurable on Magnetic Pick up/Alt., 4 configurable)



The control module display

- Generator voltage
- Generator frequency
- Battery voltage
- Engine speed
- Load current
- Engine run-time Hours
- Engine oil pressure (Panel Meter)
- Engine coolant temperature (Panel Meter)

Protecting Functions

- Over frequency / under frequency
- Over voltage / under voltage
- Over current
- Over speed /under speed
- Emergency stop
- Low oil pressure
- High water temperature
- Failure to start/Failure to stop
- Battery charger failure
- Comprehensive shutdown or warning on fault condition

Control System

NSM-100-7320 (Optional)

NSM-100-7320 is an advanced control module based on micro-processor, It is an Auto Mains (Utility) Failure Control Module(AMF), have been designed to start and stop generating sets that include electronic And non-electronic engines. Include the additional capability of being able to monitor a mains (utility) supply. when main is not available, It can automatically start the engine and close generating sets breaker automatically, Accurately measure various operational parameters and display all values and alarms information on the LCD. In additional, it can automatically open breaker, and shutdown the engine after the main supply recovers.

Main Features

- AMF and ATS and communication and expansion function
- Designed to work with electronic or non-electronic or gas engine simultaneously. (support many kinds of engines ECU).
- Manual, Automatic, Test and remote control mode selectable.
- Monitoring and measuring operational parameters of the mains supply and genset.
- Indicating operation status, fault conditions, all parameters and alarms
- Multiple protections and multiple parameters display.
- Includes 12 inputs and eight outputs. 8 inputs are configurable and 4 outputs are configurable.
- Can be programmed using the front panel or by using the PC software.
- Support twelve languages. The language was edited by customer.
- Graded protection: pre-alarm, shutdown and electrical trip, flexible setting.
- The module can be pre-set for four operating modes and protecting parameters.
- Add DSE860 or DSE865 module, internet network monitoring can be realized.
- The firmware can be updated automatically, so customer can have the latest version.



The control module display

- Generator voltage
- Generator frequency
- Battery voltage
- Engine speed
- Load current
- Generator KVA, KW, PF
- Engine run-time Hours
- Engine oil pressure
- Engine coolant temperature
- Real time clock for time and date, overall runtime

Optional

Engine

- Water Jacket Preheater
- Fuel-water separator
- Oil pump
- Oil preheater
- Battery preheater

Alternator

- PMG excitation
- Space heater
- Winding Temperature Measuring

Generator Set

- Tools with the machine
- Coolant (-30°C)

Control System

- AMF function
- ATS control cabinet
- Double-frequency and double voltage
- Single phase
- ABB MCCB

Fuel System

- 12 / 24 hour base tank (single wall)
- Dual wall base fuel tank
- Outside fuel tank
- Automatic fuel feeding
- Fuel level indicate

Canopy

- Hired type
- Economy Oil heater
- Trailer

Contact Us

MPMC POWERTECH CORP.

Add: No. 111 Luda Rd., Luyuan Industrial Zone, Pudong Shanghai China

Tel: +86 21 60970158 Fax: +86 21 60970155

Mobile: +86-18621857018 (Robert)

E mail : sales@mpmc-china.com

Web site : www.mpmc-china.com



MPMC reserves the right to make changes in model, technical specification, color, configuration and accessories without prior notice.

Please contact the salesman before ordering.

DISTRIBUTED BY:

© 2013 by MPMC, All right reserved.



ISO9001:2008
MPMC Generating Sets

